

**ACT20P-UI-AO-DO-LP-S****Weidmüller Interface GmbH & Co. KG**

Klingenbergstraße 26

D-32758 Detmold

Germany

www.weidmueller.com

**Product image****ACT20P: The flexible solution**

- Precise and highly functional signal converters
- Release levers simplify handling

**General ordering data**

Version	Signal converter/insulator, Limit value monitoring, Input : universal U, I, R, $\theta$ , Output : 4-20 mA, (loop powered), Transistor (Alarm)
Order No.	<a href="#">1453210000</a>
Type	ACT20P-UI-AO-DO-LP-S
GTIN (EAN)	4050118259605
Qty.	1 pc(s).

Creation date October 3, 2022 6:10:08 PM CEST

Catalogue status 23.09.2022 / We reserve the right to make technical changes.

## ACT20P-UI-AO-DO-LP-S

**Weidmüller Interface GmbH & Co. KG**

Klingenbergstraße 26

D-32758 Detmold

Germany

www.weidmueller.com

## Technical data

### Dimensions and weights

Depth	113.6 mm	Depth (inches)	4.472 inch
Height	119.2 mm	Height (inches)	4.693 inch
Width	12.5 mm	Width (inches)	0.492 inch
Net weight	157 g		

### Temperatures

Storage temperature	-20 °C...70 °C	Operating temperature	-20 °C...70 °C
Humidity	10...90 %, no condensation		

### Environmental Product Compliance

REACH SVHC	Lead 7439-92-1	SCIP	2f6dd957-421a-46db-a0c2-cf1609156924
------------	----------------	------	--------------------------------------

### Input

Cable-length compensation	< ±0.002 Ω per cable resistance Ω	Influence of the sensor cable resistance	5 Ω @ RTD- Kabel
Input current	configurable, ± 5 A DC (min. measurement range 0.5 A)	Input resistance, current	40 Ω
Input resistance, voltage	> 10 MΩ @ 600 mV, 2 MΩ	Input voltage	configurable, -150...+150 mV DC (min. measurement range 15 mV), -600...+600 mV DC (min. measurement range 50 mV), ± 12 V DC (min. measurement range 1 V), ± 28 V DC (min. measurement range 2 V), ± 300 V DC (min. measurement range 100 V), 0...1 V AC (min. measurement range 300 mV), 0...250 V AC (min. measurement range 100 V)
Number of inputs	1	Potentiometer	1.2...500 kΩ
Resistance	0...750 Ω, 0...1.5 kΩ, 0...12 kΩ	Sensor	PT100 (2-/3- wire), PT1000 (2-/3- wire), PT200, N120, Cu 10, Thermocouples: B, E, J, K, L, N, R, S, T, U
Sensor supply	0.1 mA / 0.05 mA (depending on measuring range) @ RTD cable	Temperature input range	CU10: -100...+260 °C, Ni120: -80 °C...+320 °C, PT100 / 200 / 1000: -200 °C...+850 °C, B: +100...+1820 °C, E: -270...+1000 °C, J: -270...+1200 °C, K: -270...+1372 °C, L: +100...+900 °C, N: -180...+1300 °C, R: -50...+1768 °C, S: -50...+1768 °C, T: -270...+400 °C, U: -200...+600 °C
Type	Universal signal isolator / signal amplifier, thermocouple, RTD		

Creation date October 3, 2022 6:10:08 PM CEST

Catalogue status 23.09.2022 / We reserve the right to make technical changes.

2

## ACT20P-UI-AO-DO-LP-S

**Weidmüller Interface GmbH & Co. KG**

Klingenbergstraße 26

D-32758 Detmold

Germany

www.weidmueller.com

## Technical data

### Output

Type	passive, connected control must be active
------	--

### Output (digital)

Alarm function	configurable, Top and bottom limit values, window range, Alarm delay: 0...99 s	Hysteresis	≥ 0.1 % of FS
Number of digital outputs	1	Rated switching current	20 mA
Rated switching voltage	≤ 30 V DC	Type	Transistor, open collector

### Output (analogue)

Number of analogue outputs	1	Output current	4...20 mA (current loop)
Signal output	direct or inverted		

### General data

Accuracy	< 0.1 % of measuring range	Cold-junction compensation error	±1.0°C @ -20° C - 65°C
Configuration	With FDT/DTM software	Galvanic isolation	2-way isolator, between input/output
Rail	TS 35	Step response time	450 ms
Temperature coefficient	< 0.02 °C of measuring range / °C	Type of connection	Screw connection
Voltage supply	Output loop powered, (10...45 V)		

### Insulation coordination

Galvanic isolation	2-way isolator, between input/output	Impulse withstand voltage	4 kV (1.2/50 µs)
Insulation voltage	3.51 kV between input and output	Pollution severity	2
Rated voltage	300 V <sub>eff</sub>	Surge voltage category	III

### Connection data

Type of connection	Screw connection	Tightening torque, min.	0.4 Nm
Tightening torque, max.	0.6 Nm	Clamping range, rated connection	2.5 mm <sup>2</sup>
Clamping range, min.	0.5 mm <sup>2</sup>	Clamping range, max.	2.5 mm <sup>2</sup>
Wire connection cross section AWG, min.	AWG 26	Wire connection cross section AWG, max.	AWG 12

### Classifications

ETIM 6.0	EC002653	ETIM 7.0	EC002653
ETIM 8.0	EC002653	ECLASS 9.0	27-21-01-20
ECLASS 9.1	27-21-01-90	ECLASS 10.0	27-21-01-20
ECLASS 11.0	27-21-01-20	ECLASS 12.0	27-21-01-20

**ACT20P-UI-AO-DO-LP-S****Weidmüller Interface GmbH & Co. KG**

Klingenbergstraße 26

D-32758 Detmold

Germany

www.weidmueller.com

**Technical data****Important note**

## Product information

The ACT20P-UI-AO-DO-LP-X converts and isolates current, voltage, potentiometer and temperature sensor signals (mA, A, mV, V, potentiometer, RTD and TC). The transmit function between the input and output can be set via the configuration program either to predefined functions (x0.5, x, x2) or via a freely definable function table. The device is powered via the output current loop.

## Features

- Configuration and monitoring are performed via FDT/DTM-Software „WI-Manager“.
- The active or passive signal inputs for RTD, TC, potentiometer, mV, V, mA and A are completely electrically isolated.
- The TC signal input has internal cold-junction compensation.
- Alarm output (for example, for limit monitoring, sensor error detection and more)
- 3-way galvanic isolation between input, output/supply and alarm output.

**Approvals**

## Approvals



## Approvals

CULUS;

## ROHS

Conform

**Downloads**

## Approval/Certificate/Document of Conformity

[UL Certification](#)  
[Declaration of Conformity](#)

## Engineering Data

[CAD data – STEP](#)

## Engineering Data

[EPLAN, WSCAD, Zuken E3.S](#)

## Software

[Library and function block – WI-Manager, DTM-Library for online installation V.1.2.3](#)  
[Release notes for Weidmueller FDT-DTM Software version 1.2.3.](#)

## User Documentation

[Instruction sheet](#)  
[20210120 Security Advisory - WI-Manager affected by MundM Software fdtCONTAINER vulnerability](#)

## Catalogues

[Catalogues in PDF-format](#)

## Brochures

**ACT20P-UI-AO-DO-LP-S**

**Weidmüller Interface GmbH & Co. KG**  
 Klängenbergstraße 26  
 D-32758 Detmold  
 Germany

www.weidmueller.com

**Drawings**

**Connection diagram**

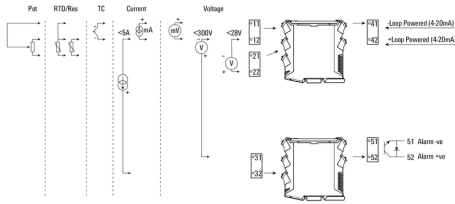

**Dimensioned drawing**

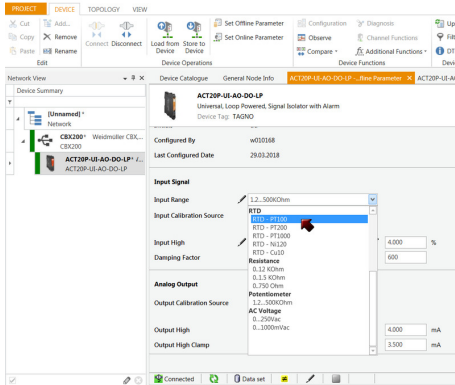
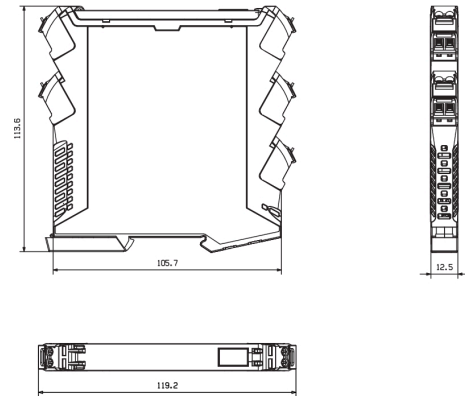

screenshot of configuration with FDT2 / DTM software

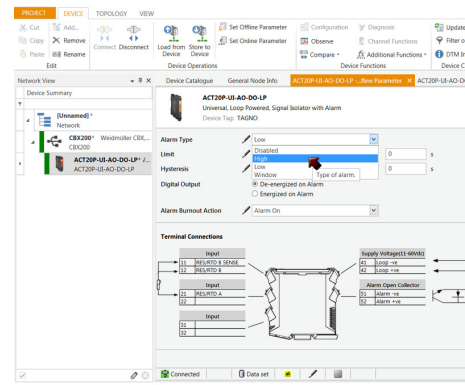

screenshot of configuration with FDT2 / DTM software

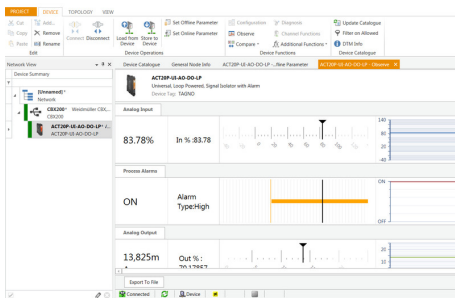

screenshot of "observe" with FDT2 / DTM software"

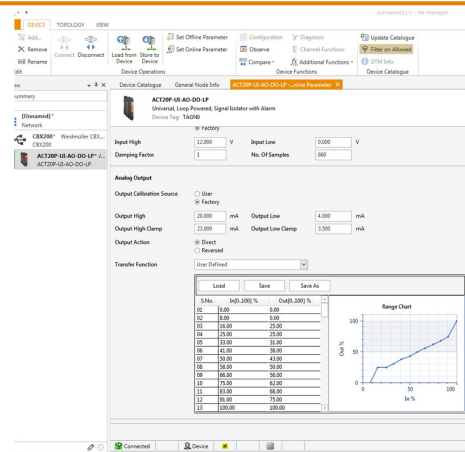

example of user defined transfer function for assigning customized output values